

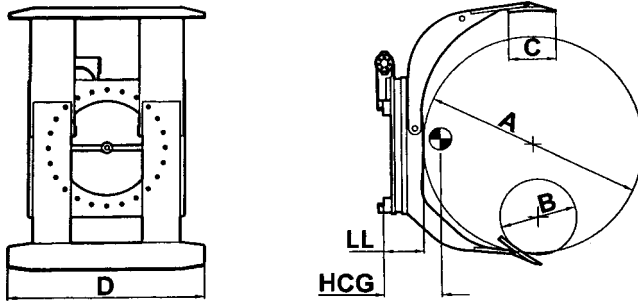

PRC model shown



Model	Cap. @ Roll Ø	To Fit Cl	A-B	B*	C	D	LL	HCG	VCG	Wt
PRA#AA			mm	mm	mm	mm	mm	mm	mm	kg
2 009 110	900	II	1100-350	250	200	700	178	200	350	430
2 009 140	900	II	1400-350	250	200	700	178	205	350	480
2 013 115	1300	II	1150-400	250	250	750	186	220	375	490
2 013 130	1300	II	1300-400	250	250	750	186	230	375	525
2 020 130	2000	II	1300-400	250	250	850	202	235	425	620
3 020 130	2000	III	1300-400	250	250	850	202	235	425	750
3 020 160	2000	III	1600-400	250	250	850	202	240	425	820
3 026 130	2600	III	1300-550	300	250	900	215	245	455	870
3 026 160	2600	III	1600-750	480	250	900	215	255	455	940
3 030 130	3000	III	1300-400	250	300	1015	225	260	550	990
4 036 180	3600	IV	1800-750	480	300	1050	255	275	550	1440

B\* with positionable short arm

#PRA = Single long, fixed short

#PRB = Single long, positionable short

#PRC = Split long, fixed short

#PRD = Split long, positionable short

## PAPER ROLL CLAMPS

These roll clamps are designed for heavy duty applications in the paper, printing and transport industries. With the popular 360° degree rotation and great forward visibility, they are practical and easy to use.

If handling small, butt rolls or if holding rolls of varying diameter in the centre of the clamp is important, choose a positionable short arm model. By rotating the clamp to 45°, the position of the short arm can be adjusted to suit the precise dimensions of the required lift.

If handling two rolls at once, choose a split long arm model. Whether these rolls are of different diameter or nominally the same, having two long arms ensures that both rolls are securely held, hence complying with required standards.

### Features:

- ✓ 360° continuous rotation
- ✓ Great visibility
- ✓ Sturdy robust construction
- ✓ Large cylinders to give more "squeeze"
- ✓ Quick and easy to install

### Options:

- ? Positionable short arm to handle larger range of rolls
- ? Split long arm to handle different sized rolls at the same time
- ? Various pads to protect paper from damage
- ? Hose reels, solenoid valves and buttons for easy hydraulic installation
- ? 3 Positional relief valves and clamp force gauges

**Sattach Pty Ltd**

305 Hanson Road  
Wingfield, South Australia, 5013  
ABN 78 010 459 613

Telephone: +61 8 8268 4111  
Facsimile: +61 8 8268 4611  
Email: [sales@sattach.com.au](mailto:sales@sattach.com.au)

P5

Branches:

NSW: 0416 244 355  
VIC: 0419 871 847  
QLD: 0417 766 521  
WA: 0407 148 879

FEB 06